



DUNCAN & EBBETT



***TAURANGA YACHT & POWER BOAT CLUB (Inc)***  
***CENTREBOARD CLASSES WINTER SERIES***  
***AT THE***  
***Tauranga Yacht and Power Boat Club (Inc)***

***Organising Authority:***

***TAURANGA YACHT AND POWER BOAT  
CLUB(Inc.) [TYPBC]***

*PO Box 14352, Tauranga. Phone (64) 07 578 5512 Fax 07 578 5595*

*Email [office@yacht.org.nz](mailto:office@yacht.org.nz)*

---

## **SAILING INSTRUCTIONS**

### **1 RULES**

- 1.1\*** The regatta will be governed by the rules as defined in *The Racing Rules of Sailing* and the Class Rules.
- 1.2** The Yachting New Zealand Safety Regulations Part 1 shall apply.
- 1.3** Racing rule A4.1 will be changed to 'a boat starting later than 10 minutes after starting signal will be scored DNS'.  
Racing Rule 61.1 (a) (2) will be changed so that P class, Starling & optimist boats are not exempt from displaying a red flag.  
Racing rule 41 will be changed to add clause (f) TYPBC patrol boats may assist in the form of coaching during racing  
Racing rule 27.1 will be changed to no later than the Preparatory the race committee signal boat will display the course number.
- 1.4** Appendix T, Arbitration will apply

## **2 NOTICES TO COMPETITORS**

Notices to competitors will be posted on the official notice board located in the basement of the TYPBC.

## **3 CHANGES TO SAILING INSTRUCTIONS**

Any change to the Sailing Instructions will be posted before 1030 hours on the day it will take effect.

## **4 SIGNALS MADE ASHORE**

**4.1** Signals made ashore will be displayed on the TYPBC flag pole.

**4.2** Flag D with one sound means ‘The warning signal will be made not less than 30 minutes after flag D is displayed. Boats are requested not to leave the beach until this signal is made.

**4.3** When flag Y is displayed ashore, rule 40 applies at all times while afloat. This changes the Part 4 preamble.

**4.4** When a visual signal is displayed over a class flag it applies to that class only.

## **5 SCHEDULE OF RACES**

**5.1** Dates of racing:

Race Day 1	Sunday	19 <sup>th</sup>	May 2019	at 1030hrs at TYPBC
Race Day 2	Sunday	16 <sup>th</sup>	June 2019	at 1030hrs at TYPBC
Race Day 3	Sunday	30 <sup>th</sup>	June 2019	at 1030hrs at TYPBC
Race Day 4	Sunday	14 <sup>th</sup>	July 2019	at 1030hrs at TYPBC
Race Day 6	Sunday	28 <sup>th</sup>	July 2019	at 1030hrs at TYPBC
Race Day 7	Sunday	11 <sup>th</sup>	August 2019	at 1030hrs at TYPBC
Race Day 8	Sunday	25 <sup>th</sup>	August 2019	at 1030hrs at TYPBC

**5.2** The scheduled time of the warning signal for the first race each day is 1125hrs.

**5.3** The warning signal for a subsequent race for a class on the same day

will be made as soon as practicable but not sooner than 2 minutes after the last boat finishes the previous race for that class.

**5.4** The format of racing will be determined by the race committee and advised at each day's briefing.

**5.5** No races shall be started after 1530 hours.

## **6 CLASS FLAGS**

Class flags will be:

<i>Class</i>	<i>Flag</i>
Bic Fleet	Numeral Pennant No.0
Green Fleet	Numeral Pennant No.1
Optimist	Numeral Pennant No.2
P Class	Numeral Pennant No.3
Starling	Numeral Pennant No.4
Zephyrs	Numeral Pennant No.5
3.7	Numeral Pennant No.6
Crewed Centreboard	Numeral Pennant No.7
Open Centreboard	Numeral Pennant No.8
Board Sailors	Numeral Pennant No.9

**A minimum of 3 boats constitutes a class.**

## **7 RACING AREAS**

Racing Area is the inner Tauranga Harbour.

## **8 THE COURSES**

**8.1** The diagrams in Attachment 1 show the courses, including the approximate angles between legs, the order in which marks are to be passed, and the side on which each mark is to be left. Alternative courses may be described at the briefing.

**8.2** No later than the preparatory signal, the race committee signal boat will display the course letters and numbers with black graphics on a white board.

## **9 MARKS**

**9.1** Marks will be cylindrical buoys approx. 1.5 meters high.

**9.3** New marks, as provided in instruction 12.1, will be described at briefing.

**9.4** The starting and finishing marks will be a race committee boat at one end and a red round buoy at the other end. There will be a starting mark on the port side of the committee boat and a finishing mark on the starboard side of the committee boat.

**9.5** A race committee boat signalling a change of a leg of the course is a mark as provided in instruction 11.2.

## **10 THE START**

**10.1** The starting line will be between a staff displaying an orange flag on the committee boat at the starboard end and the port end starting mark.

**10.2** A boat starting later than 10 minutes after her starting signal will be scored Did Not Start without a hearing. This changes rule A4.

**10.3** Boats whose warning signal has not been made shall avoid the starting area. **Failure to do so may result in a three point scoring penalty or disqualification.**

**10.4** When a subsequent race or series of races are started on the same day the warning signal of the first class to start will be preceded by the display of a postponement signal for at least 1 minute. This instruction will not apply after a general recall or abandonment.

## **11 CHANGE OF THE NEXT LEG OF THE COURSE**

**11.1** To change the next leg of the course, the race committee will lay a new mark (or move the finishing line) and remove the original mark as soon as practicable. When in a subsequent change a new mark is replaced, it will be replaced by an original mark.

**11.2** The boats shall pass between the race committee boat signalling the change of the next leg and the nearby mark, leaving the mark to port and the race committee boat to starboard. This changes rule 28.1.

**11.3** For all classes, rule 33 is changed so that, instead of displaying a compass bearing, the race committee will display a green flag if the direction is changed to starboard or a red flag if the direction is changed to port.

## **12 THE FINISH**

The finishing line will be between a staff displaying an orange flag at one end and the finishing mark at the other end.

### **PENALTY SYSTEM**

**For the Green Fleet classes rule 44.2 is changed so that the 720° turn is replaced by a 360° turn.**

## **13**

### **TIME LIMITS AND TARGET TIMES**



## **14**

### **14.1** Time limits are as follows:

The time limit for the first boat in each class will be one hour unless otherwise specified at the briefing.

## **15 PROTESTS AND REQUESTS FOR REDRESS**

15.1a Immediately after finishing a boat intending to protest shall, in addition to the requirements of rule 61.1(a), inform the race committee at the finishing line of her intention to protest and the identity of the boat(s) protested against. The protesting boat must receive an acknowledgement from the race committee. This changes rule 61.

15.1b For protests where only a rule of Part 2 is alleged to have been broken, an arbitration hearing will be offered prior to any formal hearing. Yachting New Zealand 4.5.5 will apply. (This changes Rule 44.1)

**15.2** Protest forms are available at the race office. Protests and requests for redress or reopening shall be delivered there within the appropriate time limit.

**15.3** For each class, the protest time limit is 60 minutes after the last boat has finished the last race of the day.

**15.4** Notices will be posted no later than 30 minutes after the protest time limit to inform competitors of hearings in which they are parties or named as witnesses. Hearings will be held in the protest room.

**15.5** Notices of protests by the race committee or protest committee will be posted to inform boats under rule 61.1(b).

**15.6** Breaches of instructions 10.4, 17, 21 and 24 will not be grounds for a protest by a boat. This changes rule 60.1(a). Penalties for these breaches may be less than disqualification if the protest committee so decides. The scoring abbreviation for a discretionary penalty imposed under this instruction will be DPI.

**15.7** On the last scheduled day of racing a request for reopening a hearing shall be delivered

- (a) within the protest time limit if the requesting party was informed of the decision on the previous day;
- (b) No later than 30 minutes after the requesting party was informed of the decision on that day.

This changes rule 66.

**15.8** On the last scheduled day of racing a request for redress based on a protest committee decision shall be delivered no later than 30 minutes after the decision was posted. This changes rule 62.2.

## **16 SCORING**

**16.1** 2 races are required to be completed to constitute a series.

**16.2** (a) When fewer than 6 races have been completed, a boat's series score will be the total of her race scores.

(b) When from 6 to 9 races have been completed, a boat's series score will be the total of her race scores excluding her worst score.

(c) When from 10 to 13 races have been completed, a boat's series score will be the total of her race scores excluding her two worst score.

(d) When more than 16 races have been completed, a boat's series score will be the total of her race scores excluding her three worst score.

(e) **Boats still racing but failing to finish within 20 minutes of the first boat to finish may be given a finishing position based on their place at the last mark they rounded. Their score will be greater than any boat who rounded further marks or who finished. This changes Rules 35 and A4.**



## 17 SAFETY REGULATIONS

### 17.1 *Check-Out and Check-In:*

Competitors shall **personally sign on** downstairs at the TYPBC before going afloat and shall **personally sign off** immediately on coming ashore. **Also** a boat must check in when they reach the course area by sailing across the stern of the committee boat on starboard tack, hail their sail number, and receive confirmation.

**Failure to do so will result in a three point scoring penalty and may result in disqualification.**

17.2 A boat that retires from a race shall notify the race committee as soon as possible.

## 18 REPLACEMENT OF CREW OR EQUIPMENT

18.1 Substitution of competitors will not be allowed without prior written approval of the race committee.

18.2 Substitution of damaged or lost equipment will not be allowed unless authorized by the race committee. Requests for substitution shall be made to the committee at the first reasonable opportunity.

## 19 EQUIPMENT AND MEASUREMENT CHECKS

A boat or equipment may be inspected at any time for compliance with the class rules and sailing instructions. On the water, a boat can be instructed by a race committee measurer to proceed immediately to a designated area for inspection.

## 22 OFFICIAL BOATS

Official boats will be marked as follows: They will fly the TYPBC burgee.

## 21 SUPPORT BOATS

Except when participating in rescue operations, team leaders, coaches, parents and other support personnel shall stay outside areas where boats are racing from the time of the preparatory signal for the first fleet to start until all boats have finished or retired or the Race Committee signals a postponement or an abandonment (but not a general recall). The areas the boats are racing is defined as the area inside the course and within 100 meters of any mark, lay line, starting line, finishing line or any area where any boat that is racing is sailing or may sail. During any starting sequence, support boats in the vicinity

of the start line, shall stay at least 50 meters below the starting line and its extensions.

## **22 TRASH DISPOSAL**

Boats shall not put trash in the water.

## **23 RADIO COMMUNICATION**

Except in an emergency, a boat shall neither make radio transmissions while racing nor receive radio communications not available to all boats. This restriction also applies to mobile telephones.

**Vision Impaired People may use a radio to ensure theirs and other skipper's safety and to enable them to sail the course set by the Race Officer.**

## **24 PRIZES**

Prizes may be awarded at the conclusion of the series.

## **25 DISCLAIMER OF LIABILITY**

Competitors participate in the regatta entirely at their own risk. See rule 4,

Decision to Race. The organizing authority will not accept any liability for material damage or personal injury or death sustained in conjunction with or prior to, during, or after the regatta.

# ATTACHMENT 1

## Windward-Leeward Course

● Mark 1a

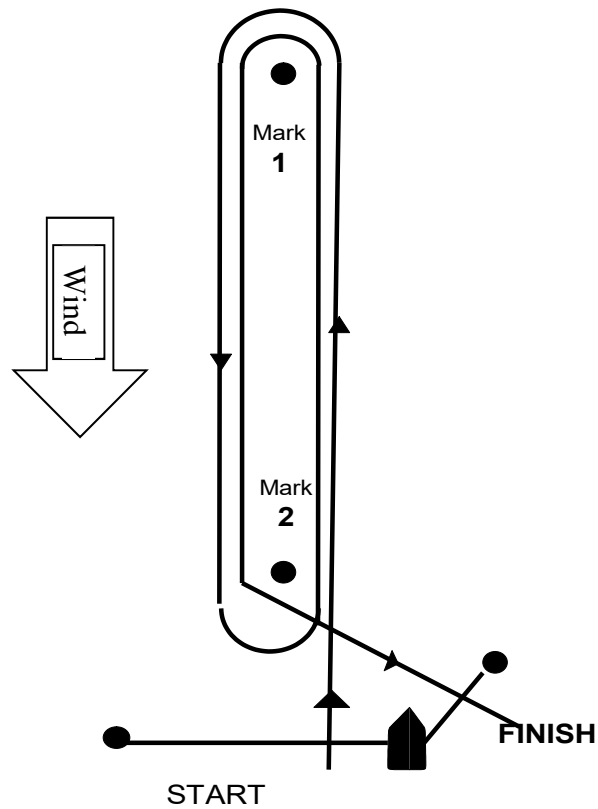

**W1 START, 1, 2, FINISH**

**W2 START, 1, 2, 1, 2, FINISH**

**W3 START, 1, 2, 1, 2, 1, 2, FINISH**

**W4 START, 1, 2, 1, 2, 1, 2, 1, 2, FINISH,**

**Mark 1a will be used by some classes as described at briefing**

## A Triangle Course- Windward-Leeward

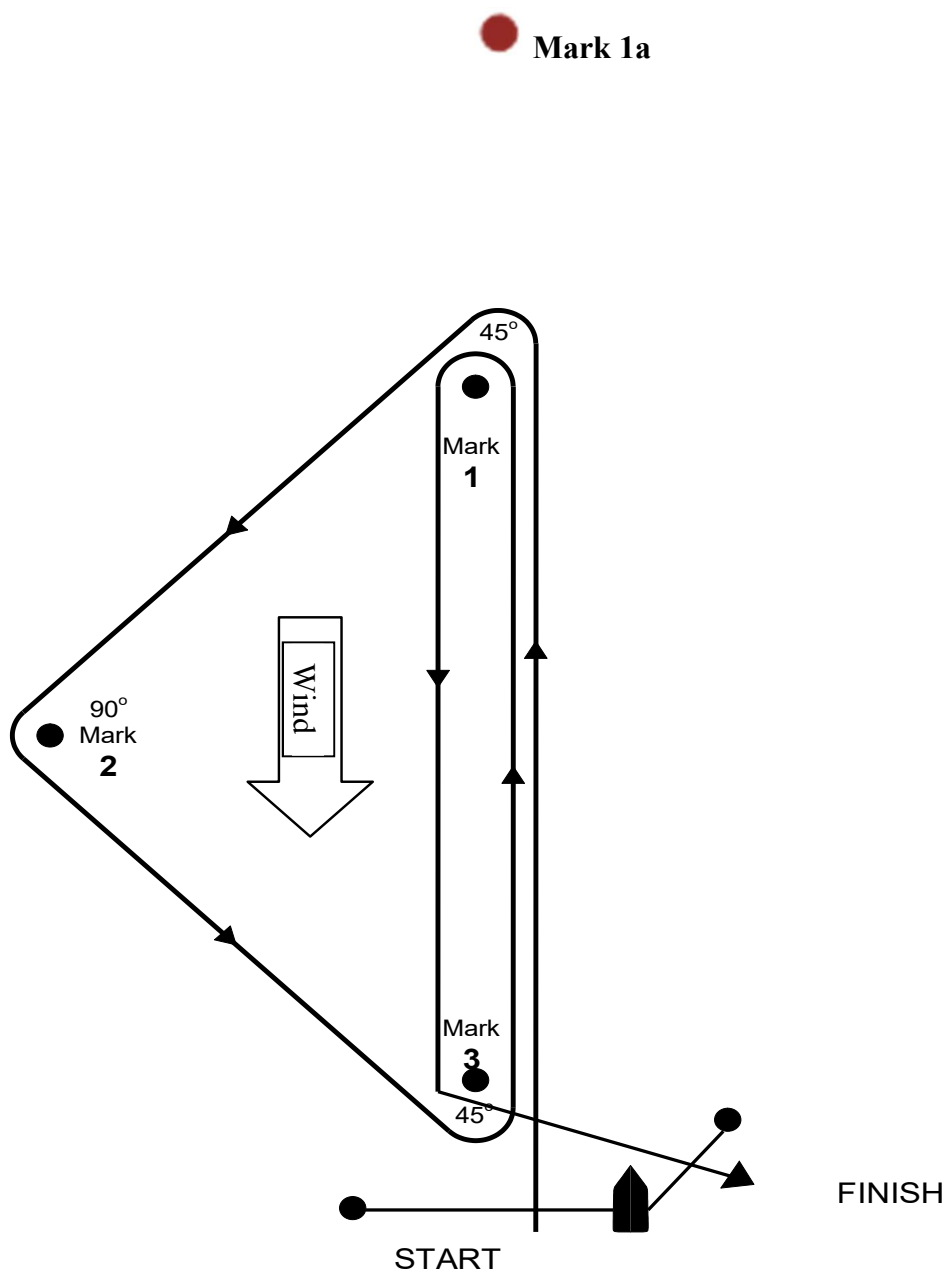

**T1 Start - 1 - 2 - 3 - Finish**

**T 2 Start - 1 - 2 - 3 - 1 - 3 - Finish**

**T 3 Start - 1 - 2 - 3 - 1 - 3 - 1 - 3 - Finish**

**T 4 Start - 1 - 2 - 3 - 1 - 3 - 1 - 2 - 3 - 1 - 3 - Finish**

**Mark 1a will be used by some classes as described at briefing**