



Steve's Marine TAURANGA REGATTA

10th and 11th February 2018

at

Tauranga Yacht and Power Boat Club (Inc)

The Organising Authority is Tauranga Yacht and Power Boat Club Inc,

Sulphur Point P O Box 14532, Tauranga.

Phone (07) 5785512 Fax (07) 5785595

Sailing Instructions

1.0 Rules

- 1.1 The regatta will be governed by the 'rules' as defined in the *Racing Rules of Sailing* and the class rules.
- 1.2 The YNZ Safety Regulations Part 1 shall apply.
- 1.3 Racing Rule 61.1 (a) (2) is changed so that all classes are **not** exempt from displaying a red flag.

Racing rule A4.1 will be changed to 'a boat starting later than 5 minutes after starting signal will be scored DNS'

Racing rule 27.1 will be changed to no later than the Preparatory the race committee signal boat will display the course number.

- 1.4 For protests where only a Rule of Part 2 is alleged to have been broken arbitration hearing will be offered prior to any formal hearing.

2.0 Notices to Competitors

Notices to competitors will be posted on the official notice board located downstairs at TYPBC.

3.0 Changes to Sailing Instructions

Any change to the Sailing Instructions will be posted before 0900 hours on the day it will take effect, Except that any change to the schedule of races will be posted by 1800 hours on the day before it takes effect.

4.0 Signals Made Ashore

- 4.1 Signals made ashore will be displayed on the clubhouse flagpole.

- 4.2 Flag D with one sound means ‘The warning signal will be made not less than 30 minutes after flag D is displayed. Boats are requested not to leave the beach until this signal is made.
- 4.3 When flag Y is displayed ashore, Rule 40 applies at all times while afloat. This changes the Part 4 preamble.
- 4.4 When a visual signal is displayed over a class flag it applies to that class only.

5.0 Schedule of Races

- 5.1 No practice race is scheduled.
- 5.2 6 races for all classes are scheduled for the series.

<i>Date</i>	<i>Number of Races</i>
10 th Feb 2018	3 races
11 th Feb 2018	3 races

- 5.3 One extra race per day may be sailed, provided that no class becomes more than one race ahead of schedule.
- 5.4 The scheduled time of the warning signal for the first race on Saturday 10th February 2018 is 1055 hours and on Sunday 11th February 2018 is 1025 hours.
- 5.5 The warning signal for a subsequent race for a class on the same day will be made as soon as practicable but not sooner than 5 minutes after the last boat finishes the previous race for that class.
- 5.6 On the last day of the regatta no warning signal will be made after 1600 hours.

6.0 Class Flags

Class flags will be:

<i>Class</i>	<i>Flag</i>
Multi hulls	Numeral Pennant No.0
Green Fleet	Numeral Pennant No.1
Optimist	Numeral Pennant No.2
P Class	Numeral Pennant No.3
Starling	Numeral Pennant No.4
Zephyrs	Numeral Pennant No.5
3.7	Numeral Pennant No.6
Crewed Centreboard	Numeral Pennant No.7
Open Centreboard	Numeral Pennant No.8
Board Sailors	Numeral Pennant No.9

A minimum of 3 boats constitutes a class.

7.0 Racing Areas

Will be within the confines of the Tauranga Harbour.

8.0 The Courses

The diagrams in Attachment 1 show the courses, including the approximate angles between legs, the order in which marks are to be passed, and the side on which each mark is to be left.

9.0 Marks

- 9.1 The course marks will be yellow cylindrical buoys approximately 1.5 metres high.
- 9.2 New mark as provided in instruction 12.1 will be a red cylindrical buoy.
- 9.3 The starting and finishing marks will be the race committee signal boat at one end and a round a red buoy at the other end.
- 9.4 A race committee boat signalling a change in course is a mark as provided in instruction 12.2.

10.0 The Start

- 10.1 The starting line will be between a staff displaying an orange flag on the starting mark at the starboard end and the port end starting mark.
- 10.2 Boats whose warning signal has not been made shall avoid the starting area.
- 10.3 A boat starting later than five minutes after her starting signal will be scored Did Not Start. This changes rule A4.1.
- 10.4 When a subsequent race or series of races are started on the same day the warning signal of the first class to start will be preceded by the display of a postponement signal for at least 4 minute. This instruction will not apply after a general recall or abandonment.

11.0 Change of the Next Leg of the Course

- 11.1 To change the position of the next mark, the race committee will lay a new mark (or move the finishing line) and remove the original mark as soon as practicable. The change will be signalled before the leading boat has begun the leg although the new mark may not yet be in position. Any mark to be rounded after rounding the new mark may be relocated without further signalling to maintain the course configuration. When in a subsequent change a new mark is replaced, it will be replaced by an original mark.
- 11.2 When a course change is signalled boats shall pass between the race committee boat signalling the change of course and the nearby mark, leaving the mark to port and the race committee boat to starboard. This changes rule 28.1

12.0 The Finish

The finishing line will be between a staff displaying an orange flag on the race committee boat at one end and the finishing mark at the other end.

13.0 Time Limits and Target Times

- 13.1 The target time for each class will be 60 minutes. Failure to meet the target time will not be grounds for redress. This changes rule 62.1 (a).The time limit for the race is 90 minutes

13.2 Boats failing to finish within 30 minutes after the first boat sails the course and finishes will be scored Did Not Finish. This changes rules 35 and A4.1.

14.0 Protests and Requests for Redress

14.1 Immediately after finishing a boat intending to protest shall, in addition to the requirements of rule 61.1(a), inform the race committee boat at the finishing line of her intention to protest and the identity of the boat(s) protested against. The protesting boat must receive an acknowledgement from the race committee. This changes rule 61.

14.2 For protests where only a rule of Part 2 is alleged to have been broken, an arbitration hearing will be offered prior to any formal hearing. (This changes Rule 44.1)

14.3 Protest forms are available at the race office. Protests shall be delivered there within the protest time limit.

14.4 For each class, the protest time limit is 60 minutes after the committee boat returns to the marina at the end of each days racing. The same protest time limit applies to all protests by the race committee and protest committee and to requests for redress. This changes rules 61.3 and 62.2. Protest time limits will be posted.

14.5 Notices will be posted within 30 minutes of the protest time limit to inform competitors of hearings in which they are parties or named as witnesses. Hearings will be held at TYPBC beginning as soon as possible.

14.6 Notices of protests by the race committee or protest committee will be posted to inform boats under rule 61.1(b).

14.7 For the purpose of rule 64.3(b) the ‘authority responsible’ is the measurer appointed by the organising authority.

14.8 Breaches of instructions 1.4, 4.2, 11.2, 16, 17.2, 20 and 21 will not be grounds for a protest by a boat under rule 60.1(a). This changes rule 60.1(a). Penalties for these breaches may be less than disqualification if the protest committee so decides.

14.9 On the last day of the regatta a request for reopening a hearing shall be delivered:
(a) within the protest time limit if the party requesting reopening was informed of the decision on the previous day;
(b) No later than 30 minutes after the party reopening was informed of the decision on that day. This changes rule 66.

15.0 Scoring

15.1 The Low Point scoring system of Appendix A will apply.

15.2 One race is required to be completed to constitute a series.

15.3 (a) When fewer than 4 races have been completed, a boat’s series score will be the total of her race scores.

(b) When from 5 to 6 races have been completed, a boat’s series score will be the total of her race scores excluding her worst score.

16.0 Safety Regulations

16.1 Boats shall sign on downstairs at the TYPBC before going afloat and sign off when returning to shore.

In addition, a boat must check in when they reach the course area by sailing across the stern of the committee boat on starboard tack, hail their sail number, and receive confirmation from the committee boat.

Failure to do so may result in a 20% fleet size scoring penalty for a first infringement and may result in disqualification for subsequent infringements.

16.2 A boat that retires from a race shall notify the race committee as soon as possible.

17.0 Replacement of Crew or Equipment

17.1 Substitution of competitors will not be allowed without prior written approval of the race committee.

17.2 Substitution of damaged or lost equipment will not be allowed unless approved by the race committee. Requests for substitution shall be made to the committee at the first reasonable opportunity

18.0 Equipment and Measurement Checks

A boat or equipment may be inspected at any time for compliance with the class rules and sailing instructions. On the water, a boat can be instructed by a race committee measurer to proceed immediately to a designated area for inspection.

19.0 Official Boats

Official boats will be marked with a TYPBC burgee.

20.0 Support Boats

20.1 Except when requested to participate in rescue operations, team leaders, coaches, parents and other support personnel shall stay outside areas where boats are racing and are restricted to a 5 knot speed limit, from the time of the preparatory signal for the first start of a sequence of starts until all boats have finished or the race committee signals a postponement or abandonment of all races. The areas the boats are racing in is defined as the area inside the course and within 100 metres of any mark, lay line, starting line, finishing line or any area where any boat that is racing is sailing or may sail.

20.2 When the wind is less than 10 knots support boats shall not exceed 5 knots within 500m of the area where boats are racing.

23.3 Attention is drawn the relevant local council bylaws regarding wearing of lifejackets and other restrictions. In boats less than 6 metres lifejackets must be worn at all times while afloat.

21.0 Haul Out Restrictions

Unless otherwise directed by the Organising Authority, all competing boats and equipment shall be launched and retrieved from TYPBC.

22.0 Radio Communication

A boat shall neither make radio transmissions while racing nor receive radio communications not available to all boats. This restriction also applies to mobile telephones.

23.0 Prizes

Prizes will be awarded at the conclusion of the regatta.

24.0 Disclaimer of Liability

Competitors participate in the regatta entirely at their own risk. See rule 4, Decision to Race. The Organising Authority will not accept any liability for material damage or personal injury or death sustained in conjunction with or prior to, during, or after the regatta.

ATTACHMENT 1

Windward-Leeward Course

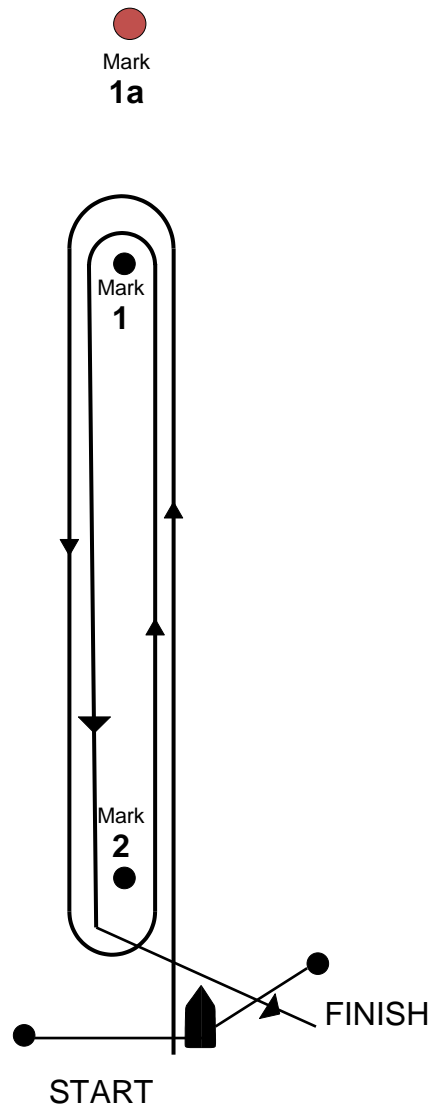

Course	Configuration
Signal	
W1	Start – 1 – 2 - Finish
W2	Start – 1 – 2 – 1 – 2 - Finish
W3	Start – 1 – 2 – 1 – 2 – 1 – 2 -Finish
W4	Start – 1 – 2 – 1 – 2 – 1 – 2 – 1 – 2 -Finish

Mark 1a will be used by some classes as described at briefing

A Triangle Course- Windward-Leeward

● Mark 1a

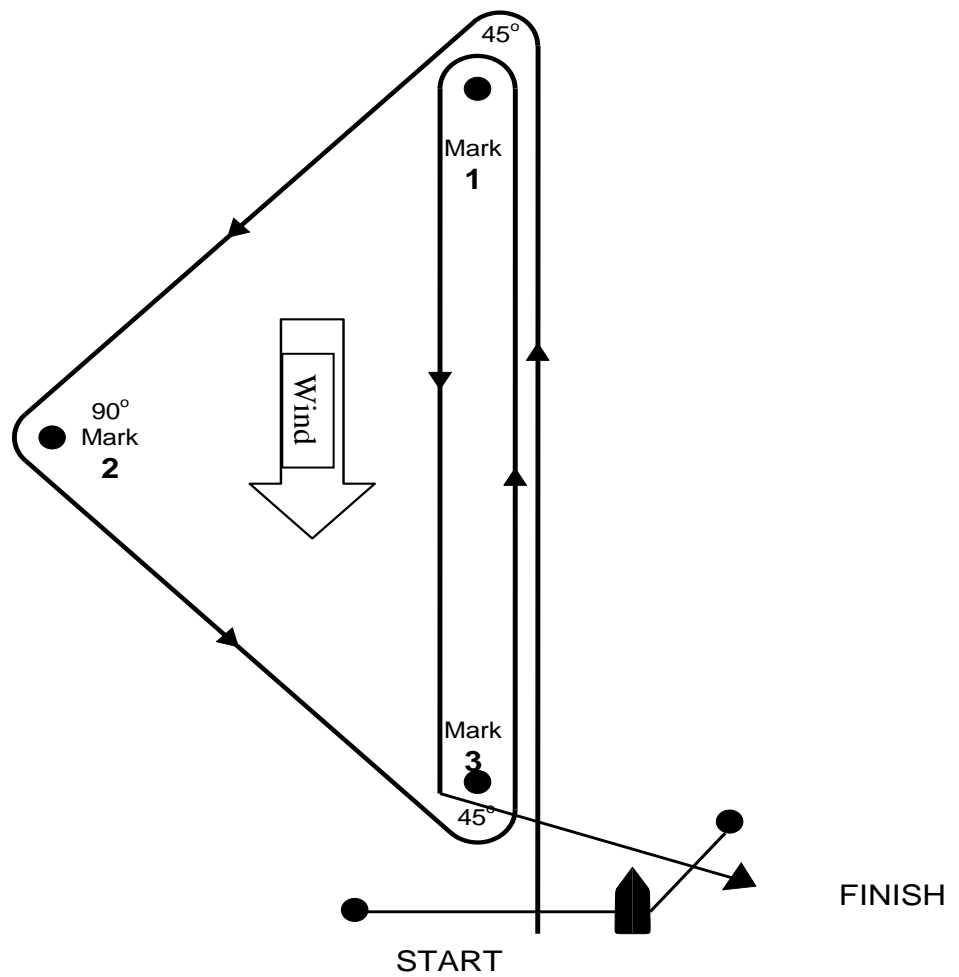

T 1 Start - 1 - 2 - 3 - Finish

T 2 Start - 1 - 2 - 3 - 1 - 3 - Finish

T 3 Start - 1 - 2 - 3 - 1 - 3 - 1 - 3 - Finish

Mark 1a will be used by some classes as described at briefing